

QUICK CX

# SPORT. UTILITY.

COMBINING THE STABILITY AND STRENGTH OF A MOUNTAIN BIKE WITH THE NIMBLENESS AND LIGHT WEIGHT OF A CITY BIKE, THE QUICK CX IS THE PERFECT ADVENTURE PARTNER.



2018

## QUICK CX 1

BRUSHED ALUMINUM (GLOSS) (RAW)

**FRAME** QUICK CX, OPTIMIZED 6061 ALLOY, SAVE

**TIRES** CONTINENTAL DOUBLE FIGHTER II, 700X37C

**SHIFTERS** SHIMANO DEORE

**FORK** HEADSHOK FATTY DL50, 50 MM

**CRANKS** SHIMANO M521, 48/36/26

**BRAKES** SHIMANO M505 HYDRAULIC DISC, 160/160MM

**WHEELS** MADDUX DC3.0

**DERAILLEURS R/F** SHIMANO SLX / ALIVIO

**SIZES** S, M, L, X, J

### > TRAVEL IN STYLE

With sleek, functional tube shapes, oversized head tubes, and suspension forks on most models, the Quick CX makes a statement on the city streets but is up to the challenges of excursions on rougher roads and bike trails.

### > SAVE VIBRATION DAMPING STAYS

Optimized rear stay shaping provides bump absorption, comfort and enhanced control with no loss in power transfer.

### > HEADS-UP RIDING

The Quick CX geometry delivers an upright, stable riding position for increased comfort, visibility and enjoyment. Relax and enjoy the ride.

# RECREATION / URBAN SPECIFICATIONS

## QUICK CX 1

<b>CODE</b>	2QRX1
<b>FRAME</b>	QUICK CX HEADSHOK, OPTIMIZED 6061 ALLOY, SAVE
<b>FORK</b>	HEADSHOK FATTY DL50, 50 MM W/LOCKOUT, OPI
<b>RIMS</b>	MADDUX DC3.0, DOUBLE WALL W/EYELET, 32 HOLE
<b>HUBS</b>	SHIMANO DEORE M595 CENTERLOCK DISC
<b>SPOKES</b>	STAINLESS STEEL, XD BLACK W/ RED NIPPLES, 15G
<b>TIRES</b>	CONTINENTAL DOUBLE FIGHTER II, 700X37C
<b>PEDALS</b>	CANNONDALE PLATFORM, REINFORCED RESIN BODY
<b>CRANK</b>	SHIMANO M521, 48/36/26
<b>BOTTOM BRACKET</b>	SHIMANO BB-ES25, OCTALINK
<b>CHAIN</b>	KMC Z99, 9-SPEED
<b>REAR COGS</b>	SHIMANO HG30, 11-32, 9-SPEED
<b>FR. DERAILLEUR</b>	SHIMANO ALIVIO
<b>REAR DERAILLEUR</b>	SHIMANO SLX
<b>SHIFTERS</b>	SHIMANO DEORE
<b>HANDLEBAR</b>	CANNONDALE C3, 6061 DOUBLE BUTTED, 20MM RISE, 620MM
<b>GRIPS</b>	CANNONDALE URBAN ERGO LOCK-ON
<b>STEM</b>	CANNONDALE C3 HEADSHOK, 3-D FORGED, 31.8, 12 DEG
<b>HEADSET</b>	TANGE SI HEADSHOK
<b>BRAKES</b>	SHIMANO M505 HYDRAULIC DISC, 160/160MM
<b>BRAKE LEVERS</b>	SHIMANO M505 HYDRAULIC DISC
<b>SADDLE</b>	CANNONDALE QUICK CX
<b>SEATPOST</b>	CANNONDALE C3, 2 BOLT, 2014 ALLOY, 31.6X350MM
<b>SIZES</b>	S, M, L, X, J
<b>COLOR 1 (CODE)</b>	BRUSHED ALUMINUM (GLOSS) (RAW)
<b>COLOR 2 (CODE)</b>	

# RECREATION / URBAN GEOMETRY

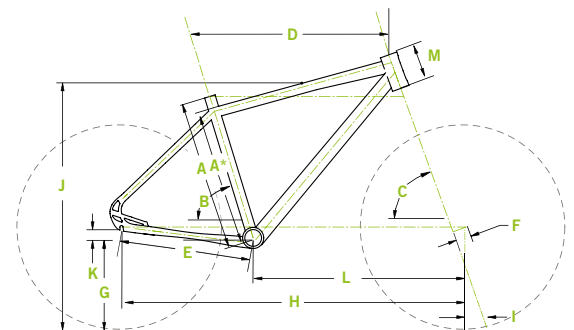

## QUICK CX HEADSHOK AND QUICK CX

SPECIFICATIONS		SMALL	MEDIUM	LARGE	X-LARGE	JUMBO
A*	MEASURED SIZE (CM/IN)*	40.2/15.8	44.2/17.4	48.2/19.5	52.2/20.5	56.2/22.1
B	SEAT TUBE ANGLE	74	73.5	73	73	72.5
C	HEAD TUBE ANGLE	69	69	70	70.5	71.5
D	HORIZONTAL TOP TUBE LENGTH (CM)	54	55	56.5	58	60.5
E	CHAIN STAY LENGTH (CM)	45	H	H	H	H
F	FORK RAKE (CM)	4.5	H	H	H	H
G	BOTTOM BRACKET HEIGHT (CM)	28.0	H	H	H	H
H	WHEELBASE (CM)	104.9	105.8	106.2	107.5	108.6
I	TRAIL (CM)	8.5	8.5	7.8	7.5	6.9
J	STANDOVER HEIGHT (CM)	76.1	79.2	82.2	85.0	87.4
J	STANDOVER HEIGHT (CM) HEADSHOK	75.3	77.9	80.0	82.4	85.0
K	BOTTOM BRACKET DROP (CM)	6.7	H	H	H	H
L	FRONT CENTER (CM)	60.7	61.6	62.1	63.3	64.5
M	HEAD TUBE LENGTH (CM) HEADSHOK	11.4	H	H	H	H
M	HEAD TUBE LENGTH (CM)	14	15	16	17	18